



User's Guide

NHD-2.4-240320YF-CTXI# **TFT**

(Liquid Crystal Display Graphic Module)

2.4" Diagonal
16-bit digital interface
240x320 Resolution (portrait mode)
White LED Backlight

Please review the controller spec ILI9320.

Tel: (847) 844-8795 Fax: (847) 844-8796

Newhaven Display International, LLC
2511 Technology Drive, #101
Elgin, IL 60124

August 10, 2007

RECORDS OF REVISION

DATE	REVISED NO.	REVISED DESCRIPTIONS	PREPARED	CHECKED	APPROVED
Aug-10-2007	1.00	FIRST ISSUE			

CONTENTS

1.	FEATURES- -----	1
2.	BLOCK DIAGRAM &APPLICATION CIRCUIT -----	1
3.	OUTLINE DIMENSIONS- -----	2
4.	INTERFACE PIN CONNECTIONS-----	4
5.	ELECTRICAL CHARACTERISTICS -----	4
6.	Electro-Optical Characteristics -----	5
7.	QUALITY GUARANTEE & INSPECTION CRITERIA ---	8
8.	RELIABILITY -----	11

1. FEATURES

ITEM	STANDARD VALUE	UNIT
LCD Type	2.4" QGVA TFT-LCD (Thin Film Transistor Liquid Crystal Display)	---
Viewing Direction	6:00	O'clock
Backlight Type	4-parallel-White LED	---
Module Outsize	42.72*60.26*3 thickness=3.8 (with TP)	mm
TP Viewing area	38.72*54.36	mm
TP Active area	37.72*53.36	mm
LCD Active area	36.72*48.96	mm
Dot Number	240(RGB) × 320	---
Dot size	0.153*0.153	mm
Operation temperature	-10 ~70	°C
Storage temperature	-30 ~80	°C
Driver IC	ILI9320	
Interface mode	8080 System 8/16 bit Interface	---

Remark:

1. Display color support 262K/65K, In detail please see also the ILI9320specification.

2. BLOCK DIAGRAM

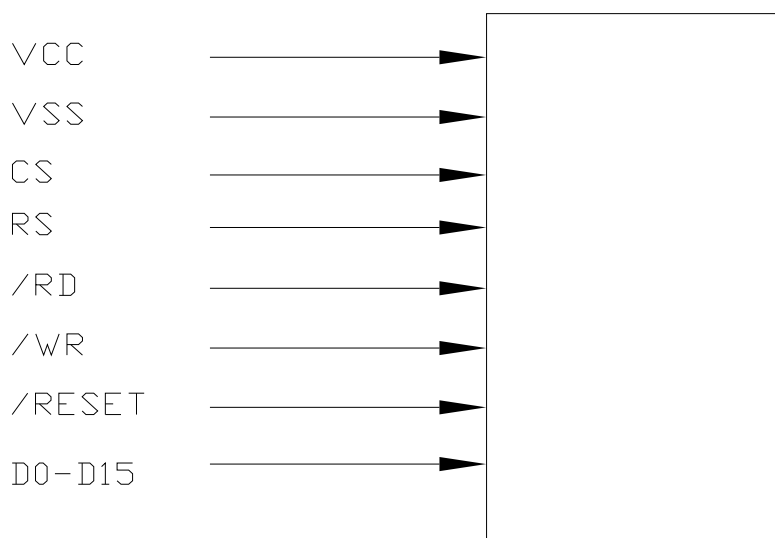

3. OUTLINE DIMENSIONS

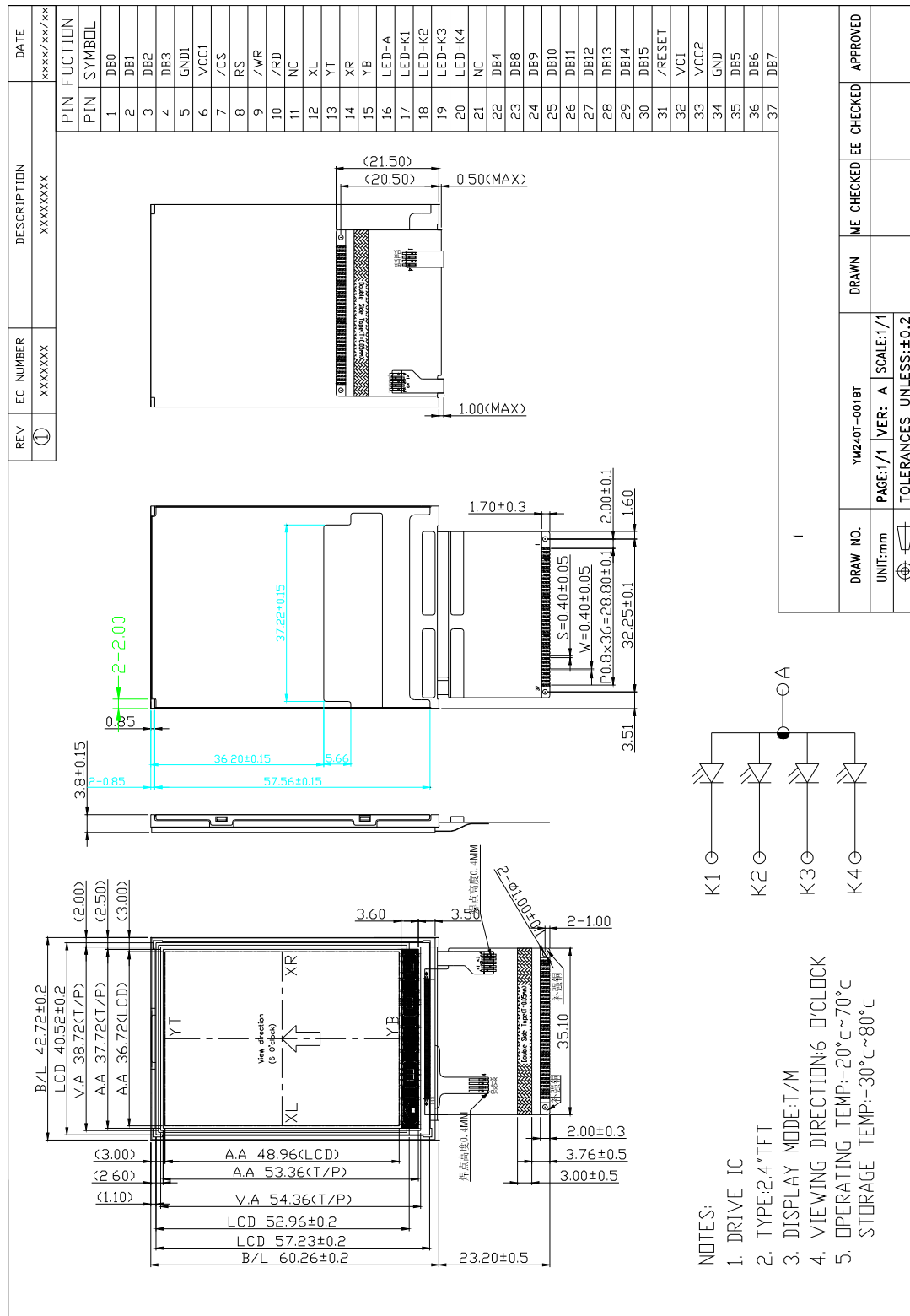

4. INTERFACE PIN CONNECTIONS

PIN	SYMBOL	FUNCTION
1	DB0	Data bus
2	DB1	
3	DB2	
4	DB3	
5	GND	Ground
6	VCC	Power supply
7	/CS	Chip select input pin (“Low” enable).
8	RS	Display data / Command selection pin
9	/WR	Write pin
10	/RD	Read pin
11	NC	No Connect
12	XL	Left electrode
13	YT	Top electrode
14	XR	Right electrode
15	YB	Bottom electrode
16	LED-A	Backlight power supply
17	LED-K1	Backlight ground
18	LED-K2	
19	LED-K3	
20	LED-K4	
21	NC	NO connect
22	DB4	Data bus
23	DB8	
24	DB9	
25	DB10	
26	DB11	
27	DB12	
28	DB13	
29	DB14	
30	DB15	
31	/RESET	Reset pin
32	VCC	Power supply
33	VCC	
34	GND	Ground
35	DB5	Data bus
36	DB6	
37	DB7	

5. ELECTRICAL CHARACTERISTICS

5.1 ABSOLUTE MAXIMUM RATING

Please Refer to the SPEC of ILI9320

6. Electro-Optical Characteristics

6.1 Backlight Unit

Item	Symbol	Min	Typ.	Max	Unit	Remark
Input voltage	V _{BL}	--	3.2	--	V	-
Current	I _{BL}	---	18	---	mA/chip	-
ICE	X	0.26	-	0.30	-	X>Y
	Y	0.27	-	0.31	-	
Brightness	-	---	3200	---	cd/m ²	
Luminous Intensity Ratio	-	---	----	20	%	-

6.2 LCD panel

Item	Symbol	Conditions	Specifications			Unit	Note	
			Min.	Typ.	Max.			
Transmittance	T%	Viewing normal angle $\theta_x = \theta_y = 0^\circ$		4.7		%	All left side data are based on CMO's following condition – Type 767 NTSC: 60% LC:5066 Light : C light (Machine:BM5A) Normal Polarizer Without DBEF	
Contrast Ratio	CR		150	250	-	-		
Response Time	T _R		NA	10	20	ms		
	T _F		NA	20	30	ms		
Chromaticity	Red		X _R	0.603	0.633	0.663		
			Y _R	0.299	0.329	0.359		
	Green		X _G	0.264	0.294	0.324		
			Y _G	0.546	0.576	0.606		
	Blue		X _B	0.103	0.133	0.163		
			Y _B	0.092	0.122	0.152		
White	X _W	0.278	0.308	0.338				
	Y _W	0.316	0.346	0.376				
Viewing Angle	Hor.	θ_{x+}		45	-	deg.		
		θ_{x-}		45	-			
	Ver.	θ_{y+}		35	-			
		θ_{y-}		15	-			

*Note (1) Definition of Contrast Ratio (CR):

The contrast ratio can be calculated by the following expression.

$$\text{Contrast Ratio (CR)} = L63 / L0$$

L63: Luminance of gray level 63

L0: Luminance of gray level 0

$$\text{CR} = \text{CR} (10)$$

CR (X) is corresponding to the Contrast Ratio of the point X at Figure in Note (6).

*Note (2) Definition of Response Time (TR, TF):

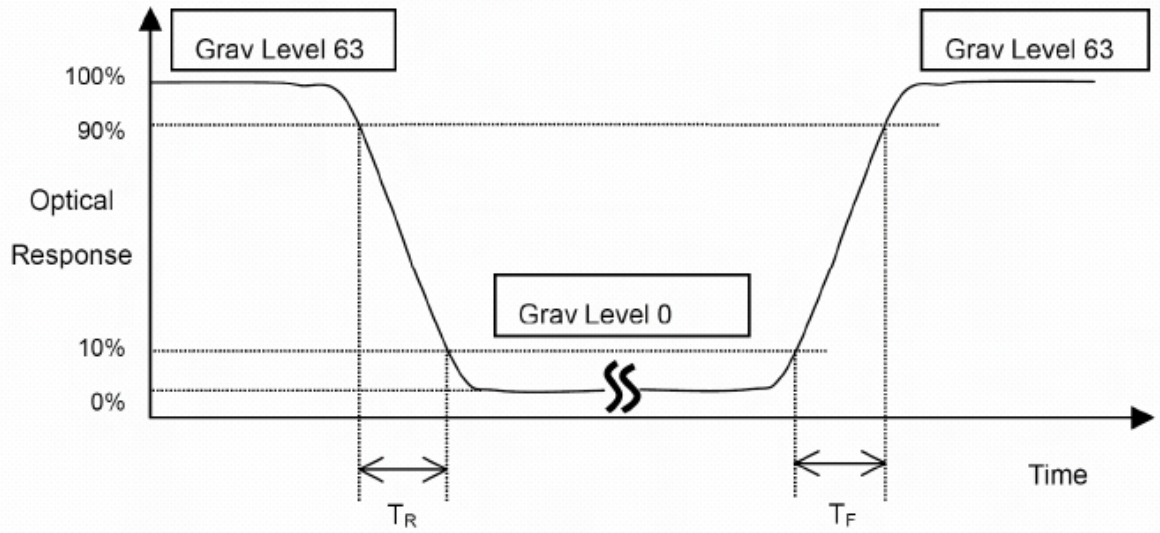

*Note(3) Definition of Viewing Angle

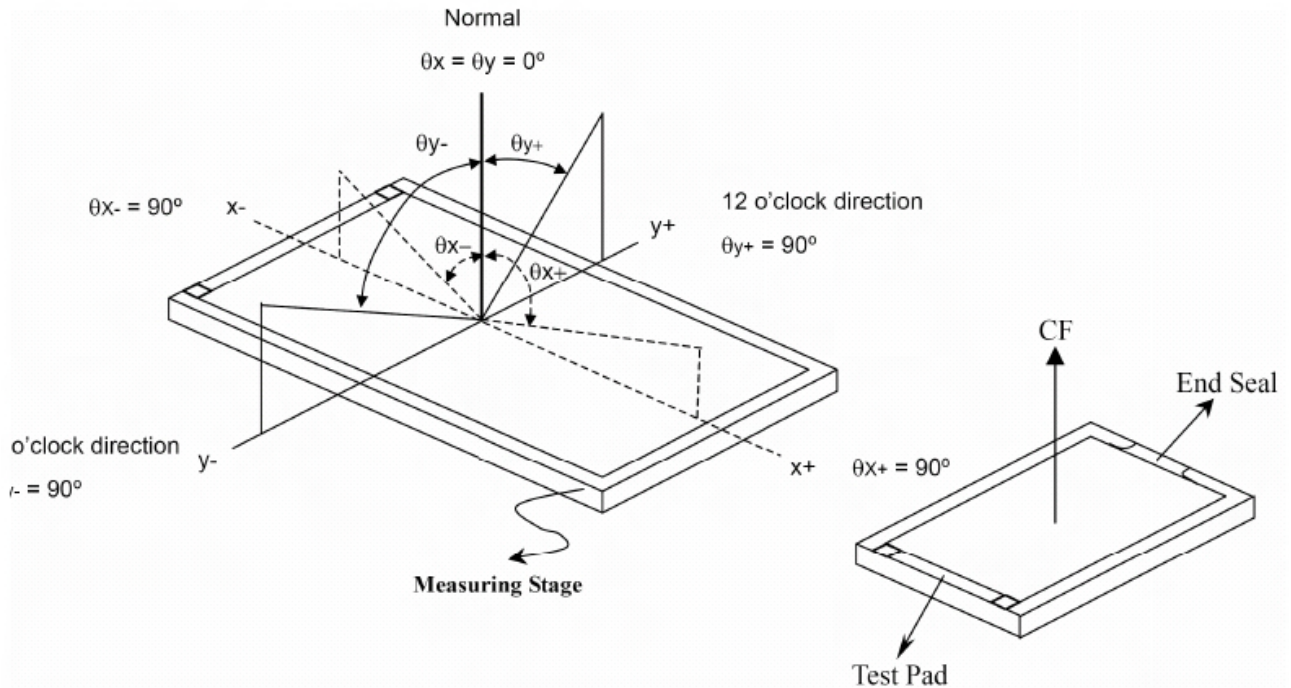

***Note (4) Measurement Set-Up:**

The LCD module should be stabilized at a given temperature for 20 minutes to avoid abrupt temperature change during measuring. In order to stabilize the luminance, the measurement should be executed after lighting Backlight for 20 minutes in a windless room.

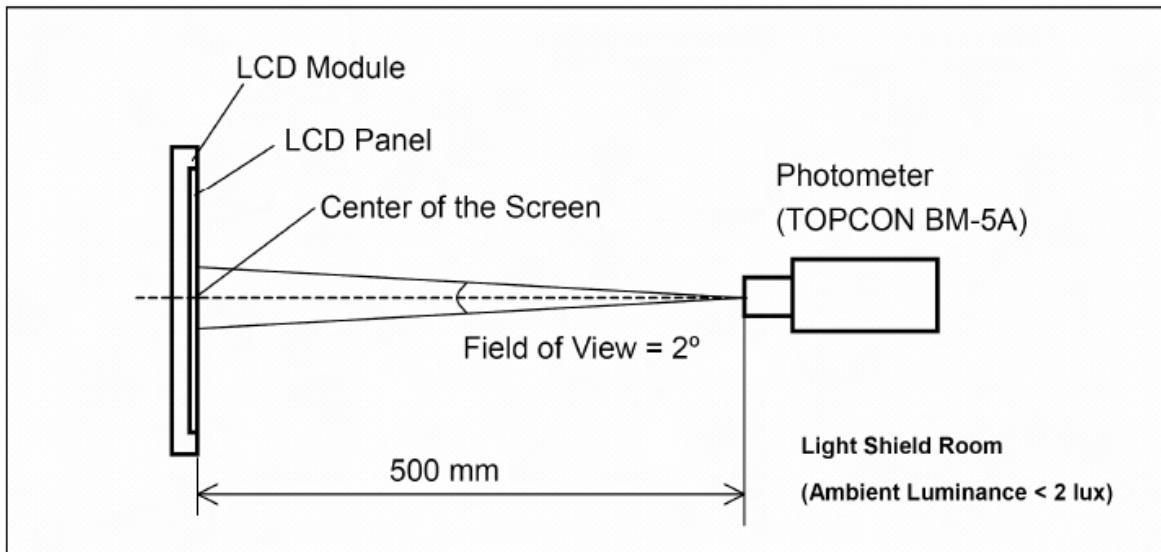

***Note (5)**

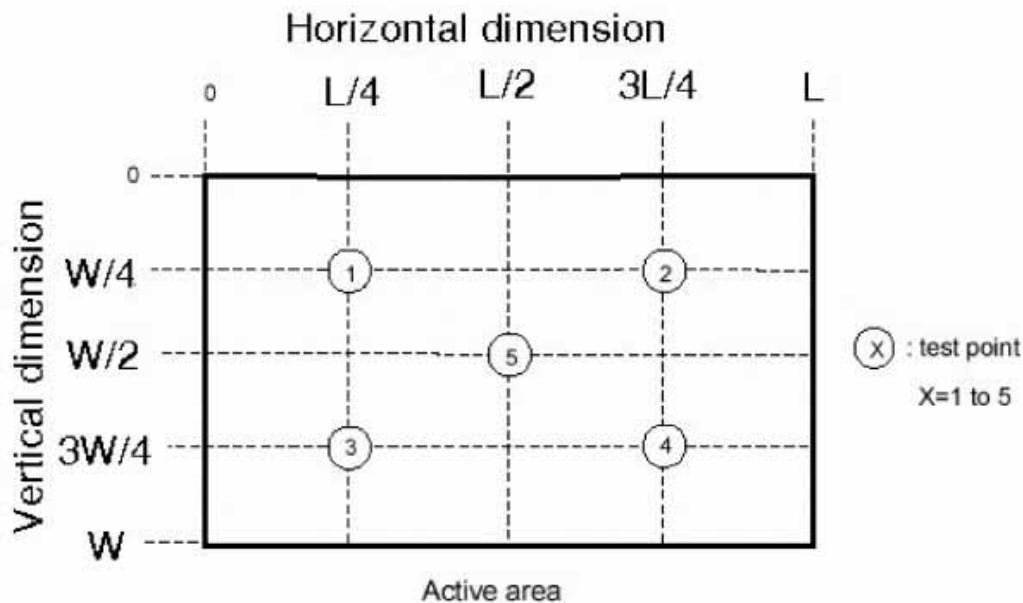

7. QUALITY GUARANTEE & INSPECTION CRITERIA

7.1 Appearance inspection

Appearance inspection should be done under the following condition.

- (1) In the dark room.
- (2) The distance from eyes to LCD must be 30 cm.
- (3) Viewing direction must be within 30 degrees to vertical line of LCD center.

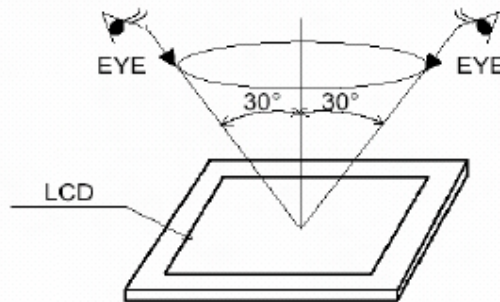

7.2 Definition of A zone, B zone and C zone

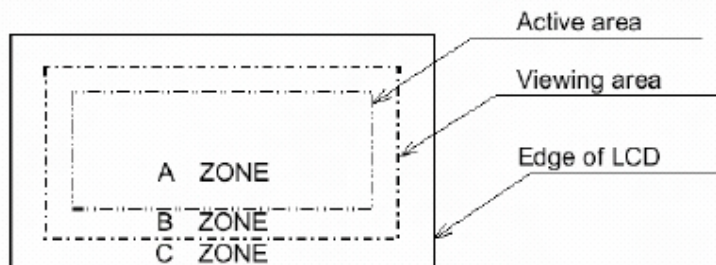

7.3 Electrical Testing

1. Missing vertical, horizontal segment, segment contrast defect.
2. Missing character, dot or icon.
3. Display malfunction.
4. No function or no display.
5. Current consumption exceeds product specifications.
6. LCD viewing angle defect.
7. Mixed product types.
8. Contrast defect

7.4 Black or white spots on LCD (display only)

1. White and black spots on display $\cong 0.20\text{mm}$, no more than three white or black spots present.
2. Densely spaced: No more than two spots or lines within 5mm

7.5 LCD black spots, white spots, contamination (non-display)

1. Round type: As following drawing

$$\psi = (x+y)/2$$

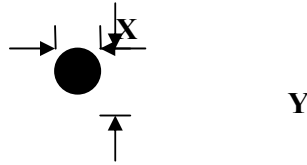

SIZE	Acceptable QTY
$\psi \leq 0.10$	Accept no dense
$0.10 < \psi \leq 0.15$	2
$0.15 < \psi \leq 0.20$	1
total	2

2. Line Type: (As following drawing)

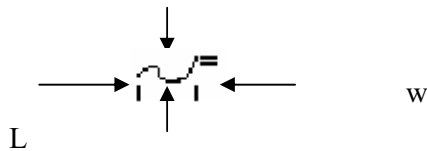

Length	Width	Acceptable QTY
---	$W \leq 0.02$	Accept no dense
$L \leq 3.0$	$0.02 < W \leq 0.03$	2
$L \leq 2.5$	$0.03 < W \leq 0.05$	
---	$0.05 < W$	As round type

7.6 Polarizer bubbles

If bubbles are visible, judge using black spot specifications, not easy to find, must check in specify direction.

Size ψ	Acceptable QTY
$\psi \leq 0.20$	Accept no dense
$0.20 < \psi \leq 0.50$	2

7.7 Chipped glass

Symbols:

a: Chip length b: Chip width c: Chip thickness

t: Glass thickness

1 ITO electrode

$a \leq t$

$b \leq 0.5\text{mm}$

$c \leq 3.0\text{mm}$

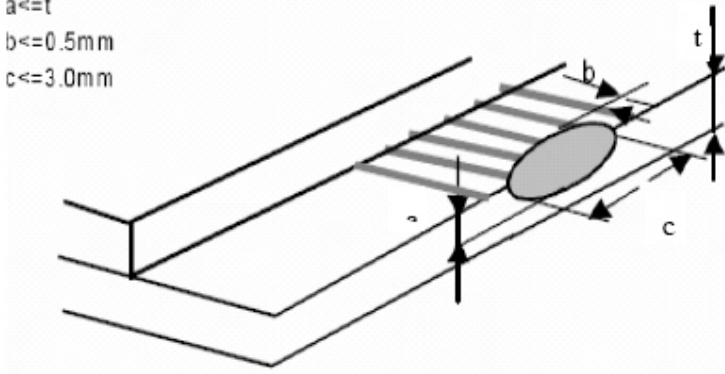

2 General ,corner portion

$a \leq t$

$b \leq 1.0\text{mm}$

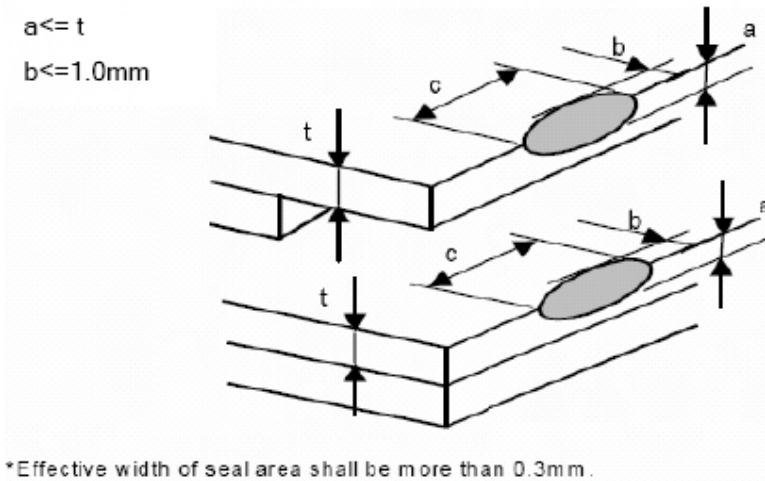

*Effective width of seal area shall be more than 0.3mm.

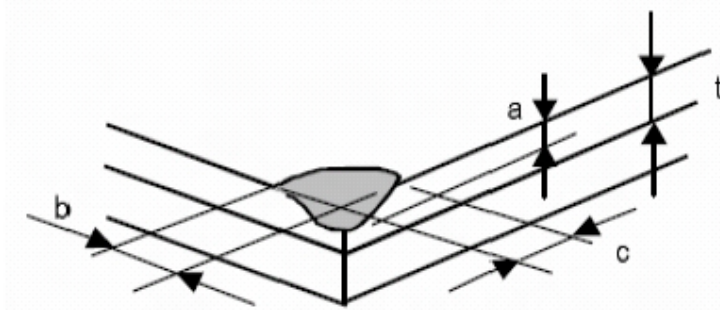

7.8 Backlight elements

1. Illumination source flickers when lit.
2. Spots or scratches that appear when lit must be judged using LCD spot, lines and contamination standards.
3. Backlight doesn't light or color is wrong

7.9 Soldering

1. No unmelted solder paste may be present on the PCB.
2. No cold solder joints, missing solder connections, oxidation or icicle.
3. No residue or solder balls on PCB.
4. No short circuits in components on PCB.

7.10 General appearance

1. No oxidation, contamination, curves or, bends on interface pin (OLB) of TCP.
2. No cracks on interface pin (OLB) of TCP
3. NO contamination, solder residue or solder balls on product.
4. The IC on the TCP may not be damaged, circuits.
5. The uppermost edge of the protective strip on the interface pin must be present or look as if it cause the interface pin to sever.
6. The residual rosin or tin oil of soldering (component or chip component) is not burned into brown or black color.
7. Sealant on top of the ITO circuit has not hardened
8. Pin type must match type in specification sheet.
9. LCD pin loose or missing pins.
10. Product packaging must the same as specified on packaging specification sheet.
11. Product dimension and structure must conform to product specification sheet.
12. The appearance of Heat Seal should not admit any dirt and break.

8. RELIABILITY

Test Item	Sample Type	Test Condition	Test result determinant gist
High temperature storage	Normal temperature	$70 \pm 3^{\circ}\text{C}; 240\text{H}$	the inspection of Appearance and function character.
	Broad temperature	$80 \pm 3^{\circ}\text{C}; 240\text{H}$	
Low temperature storage	Normal temperature	$-20 \pm 3^{\circ}\text{C}; 240\text{H}$	
	Broad temperature	$-30 \pm 3^{\circ}\text{C}; 240\text{H}$	
High temperature	Normal temperature	$50^{\circ}\text{C} \pm 3^{\circ}\text{C}, 90\% \pm 3\%\text{RH}; 240\text{H}$	

/humidity storage	Broad temperature	60°C ± 3°C, 90% ± 3%RH; 240H	
High temperature operation	Normal temperature	60 ± 3°C; 96H	No objection of the function character; no fatal objection of the appearance.
	Broad temperature	70 ± 3°C; 96H	
Low temperature operation	Normal temperature	0 ± 3°C; 96H	
	Broad temperature	-20 ± 3°C; 96H	
High temperature /humidity operation	Normal temperature	40°C ± 3°C, 90% ± 3%RH; 96H	
	Broad temperature	50°C ± 3°C, 90% ± 3%RH; 96H	
Temperature Shock	Normal temperature	-20 ± 3°C, 30min → 70 ± 3°C, 30min; 10cycle	inspect the objections appearance、function & the whole structure
	Broad temperature	-30 ± 3°C, 30min 80 ± 3, 30min; 10cycle	The inspection of appearance、function & the whole structure
ESD test	ALL	Discharge modality: Air discharge. Discharge voltage: ±2KV/±4KV/±6KV/±8KV/±12KV/15KV	.no software error & objection in ±2KV~±12KV, no hardware errors & objection in ±15KV.
		Discharge modality: Contact discharge Discharge voltage: ±2KV/±4KV/±6KV/±8KV	no software errors & objection in ±2KV~±12KV, no hardware errors & objection in ±8KV.
Bend test	ALL	Bend velocity: 60time/min; Bendtimes:50000tims	Stimulate the folder's repeat folding, no objection of display function
Vibration test	ALL	frequencyrange:10HZ~55HZ;swing:0.75mm;Z-axis direction: 60min.	the inspection of appearance、function & the whole structure

9. PRECAUTIONS FOR USING LCD MODULES

Handing Precautions

(1) The display panel is made of glass. Do not subject it to a mechanical shock by dropping it or impact.

(2) If the display panel is damaged and the liquid crystal substance leaks out, be sure not to get any in your mouth. If the substance contacts your skin or clothes, wash it off using soap and water.

(3) Do not apply excessive force to the display surface or the adjoining areas since this may cause the color tone to vary.

(4) The polarizer covering the display surface of the LCD module is soft and easily scratched. Handle this polarizer carefully.

(5) If the display surface becomes contaminated, breathe on the surface and gently wipe it with a soft dry cloth. If it is heavily contaminated, moisten cloth with one of the following solvents :

- Isopropyl alcohol
- Ethyl alcohol

(6) Solvents other than those above-mentioned may damage the polarizer. Especially, do not use the following.

- Water
- Ketone
- Aromatic solvents

(7) Exercise care to minimize corrosion of the electrode. Corrosion of the electrodes is accelerated by water droplets, moisture condensation or a current flow in a high-humidity environment.

(8) Install the LCD Module by using the mounting holes. When mounting the LCD module make sure it is free of twisting, warping and distortion. In particular, do not forcibly pull or bend the IO cable or the backlight cable.

(9) Do not attempt to disassemble or process the LCD module.

(10) NC terminal should be open. Do not connect anything.

(11) If the logic circuit power is off, do not apply the input signals.

(12) To prevent destruction of the elements by static electricity, be careful to maintain an optimum work environment.

- Be sure to ground the body when handling the LCD modules.
- Tools required for assembling, such as soldering irons, must be properly grounded.
- To reduce the amount of static electricity generated, do not conduct assembling and other work under dry conditions.

- The LCD module is coated with a film to protect the display surface. Exercise care when peeling off this protective film since static electricity may be generated.

Storage Precautions

When storing the LCD modules, avoid exposure to direct sunlight or to the light of fluorescent lamps. Keep the modules in bags (avoid high temperature, high humidity and low temperatures below 0 °C). Whenever possible, the LCD modules should be stored in the same conditions in which they were shipped from our company.

Others

Liquid crystals solidify under low temperature (below the storage temperature range) leading to defective orientation or the generation of air bubbles (black or white). Air bubbles may also be generated if the module is subject to a low temperature.

If the LCD modules have been operating for a long time showing the same display patterns, the display patterns may remain on the screen as ghost images and a slight contrast irregularity may also appear. A normal operating status can be regained by suspending use for some time. It should be noted that this phenomenon does not adversely affect performance reliability.

To minimize the performance degradation of the LCD modules resulting from destruction caused by static electricity etc., exercise care to avoid holding the following sections when handling the modules.

- Exposed area of the printed circuit board.
- Terminal electrode sections.